

Within this document we will talk about Thermal movement limiters.

Limiting the thermal expansion will prevent a socket and pipe failure from accumulative movement from all sockets within the run of pipe. This is particularly important when the pipe runs are over large distances and suspended on extended support drop rods which makes conventional bracketing difficult.

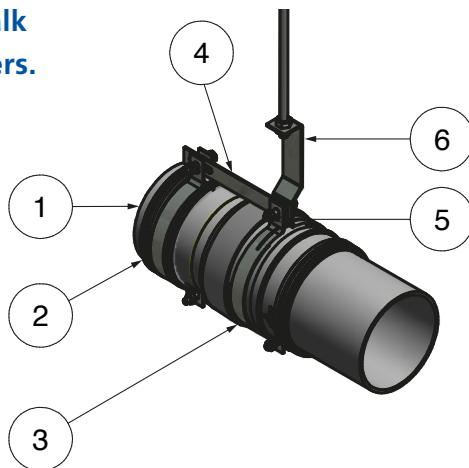

Item	Description
1	110mm PVC pipe
2	PVC split shell
3	Ring bracket
4	Slotted tie rail
5	M6 bolts and locking nut
6	Hanger plate

Method 1: Pre- assembled fit

- Pre-prepare and chamfer the pipe end.
- Measure from a pre-prepared pipe end and mark (Ref: Table A).
- Solvent Weld the Split PVC shell into position so the it sits flush with the mark on the pipe and allow for the joint to cure (Ensure the bracket groove closest to the expansion socket).
- Attach the ring brackets, hanging plate and slotted tie rail to the expansion socket & tighten - using the bolt hole (Ensuring the slotted tie is between the ring brackets, this will allow movement for the slotted tie, which allows controlled expansion within the system).
- Pull back the pipe from the socket into the mid position on the slots of the tie rails.
- Lubricate ring seal with Terrain silicone grease and insert the pipe into the expansion socket (Ensuring the pipe is pushed fully into the socket).
- Attach the ring bracket to the PVC split shell, attached the slotted tie rail and tighten - using the slotted hole (Ensuring the slotted tie is between the ring brackets, this will allow movement for the slotted tie, which allows controlled expansion within the system).

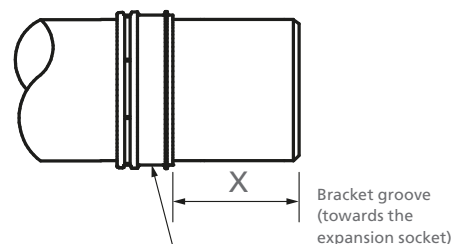
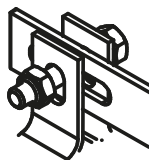

TABLE A

Pipe Size	X
82mm	Depth of expansion socket + 10mm
110mm	Depth of expansion socket + 10mm
160mm	Depth of expansion socket + 10mm



When installing bracket and slotted tie ensure the slotted tie is between the ring brackets. The slotted tie should be able to move, which allows controlled expansion within the system.

Method 2: Post assembled fit

- Ensure the pipe is pushed fully into the expansion socket.
- Mark a line where the rim of expansion socket meets the pipe and mark a second line a distance from the expansion socket (Ref: Table B).
- Position the PVC split shell so that it is flush with the second mark on the pipe (Ensure the bracket groove closest to the expansion socket).
- Solvent weld the PVC split shell and allow for the joint to cure.
- Attach the ring bracket to the PVC split shell, attach the slotted tie rail and tighten - using the slotted hole (Ensuring the slotted tie is between the ring brackets, this will allow movement for the slotted tie, which allows controlled expansion within the system).
- Pull back the pipe from the socket into the mid position on the slots of the tie rails.

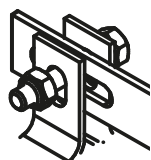
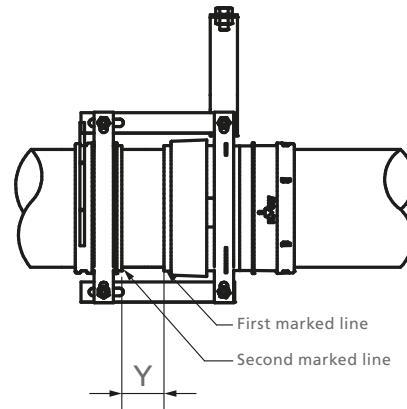

When installing bracket and slotted tie ensure the slotted tie is between the ring brackets. The slotted tie should be able to move, which allows controlled expansion within the system.

TABLE B

Pipe Size	Y
82mm	10mm
110mm	10mm
160mm	10mm



Contact Us

to find out about our Technical Workshop

Look out for the next Technical Bulletin on Hole Saws.