

MODULAR HEATING PANEL

A new concept in under floor heating

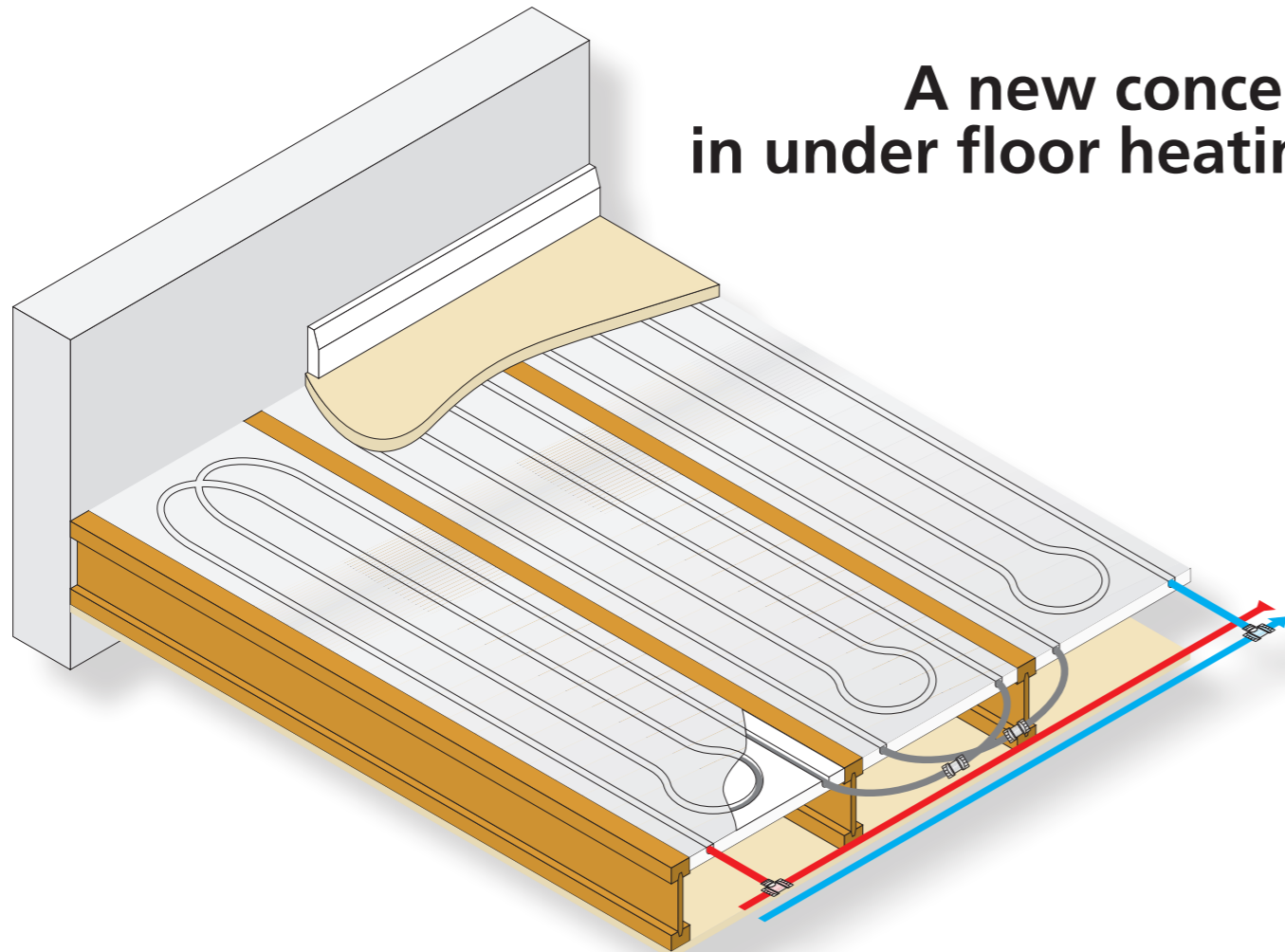

Modular Heating Panels* are an exciting new product concept from Polypipe that enable quick and simple installation of under floor heating into suspended floors in both new build and renovation projects.

Installing under floor heating into upper floors can be challenging, even in new build projects. Most conventional under floor heating systems comprise a single section of pipe, housed or placed within another part of the system structure, such as floor panels, which are cut to size on site. This works fine as there are no interruptions to the laying of the pipe. In suspended floor installations however, the pipe, plates and insulation have to fit within an obvious obstruction: the supporting floor joists. It is working around the joists, and avoiding other services, that has often led to under floor heating being avoided in upper floors.

As the name suggests, a Modular Heating Panel (MHP) is a pre-configured solution, where all of the floor heating system components are supplied fitted within complete panels, which are simply fitted and connected together on site. Thanks to MHP it is now possible to fit panels quickly into the existing joist voids and connect them to a standard heat source.

MHP works with both traditional and engineered joists and can be fitted from above or below.

*Patent pending.

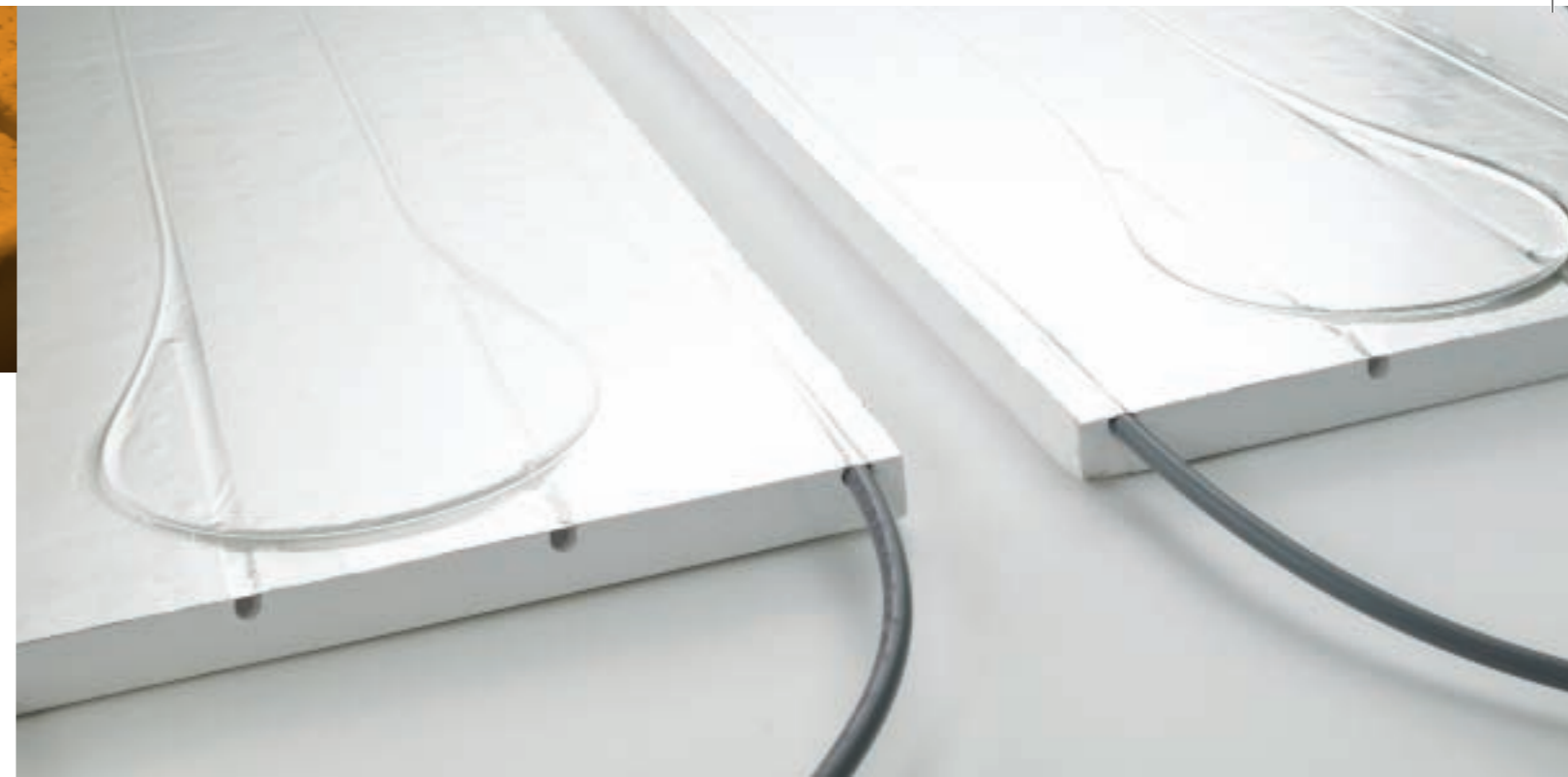

Maximising heat efficiency

Due to their high output at relatively low flow temperatures, Modular Heating Panels are ideal for maximising heat efficiency and lowering energy consumption. In most installations it is not necessary to cover the entire floor area. MHP panels work like "under floor radiators", applying enough heat to only those areas of the floor that need to be heated and using just enough of them to maintain a suitable room temperature.

For a room temperature of 20°C, for example, only 80% floor coverage is required to provide 70W/m² or around 60% for 50W/m². This unique product benefit also makes MHP an ideal solution when using heat pumps.

The flexibility of panel placement provided by MHP means that floor areas to be covered by items such as built-in wardrobes or baths and shower cubicles can be avoided without detriment to the overall heating provision.

Product options

MHP is available in 4 panel sizes comprising 2 lengths and 2 widths:

MHP available lengths: 1.3m and 2.0m

MHP available widths: 380mm and 490mm

Each MHP panel contains pre-installed pipe circuitry, 30mm of insulation, and is covered in heat diffusing foil. Pipe circuitry is based on 10mm diameter pipe. A 500mm length of pipe extends from each panel allowing connection to the flow and return pipe work from an under floor heating manifold.

MHP panels are easily installed from either above or below and suit the joist widths of both composite 'I' beam joists and traditional timber joists. Up to 3 MHP panels can be connected together in series and the recommended maximum room area per circuit is 20m².

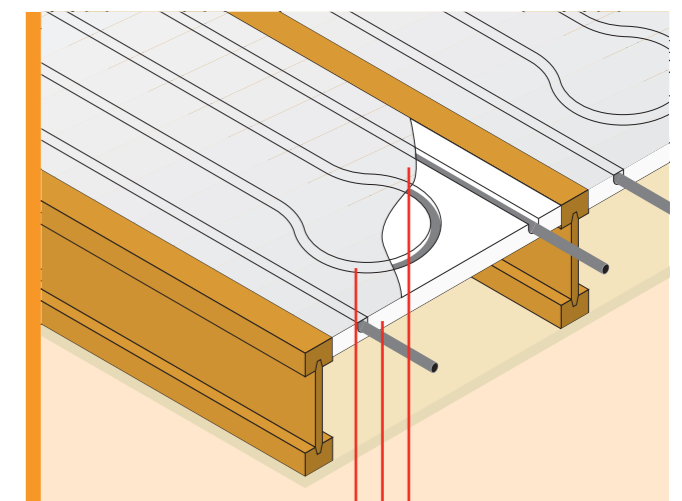

Heat diffusion foil
30mm insulation
10mm pipe circuit

Designing your layout

Designing the ideal room layout for an MHP installation and selecting the required products couldn't be simpler.

Follow the steps below or use the online product selector tool at www.ufch.com/mhp

Select panel width

Step 1:

The spacing of joists and the available gap will determine which MHP panel width will be most suitable for each project. Select the MHP width nearest to the gap width, ensuring that this does not encroach on the space for other services.

The 490mm width panel will normally be fitted in the wider joist spacing used by composite joists and 'I' beams.

Select panel length

Step 2:

The span of the joists in each room will determine which MHP panel length should be selected. The span is defined as the free space from wall to wall that needs to remain uninterrupted by trimmers or other services. Ideally, install MHP panels prior to other services whenever possible.

Use the table below as a quick guide to suitable arrangements of MHP panels leaving a 200mm gap for pipe connections.



Planning your room arrangement

Step 3:

Calculating the amount of floor area to be covered by MHP will be based on the required heat output (see our heat output tables on page 27) and will take into account areas of the floor that do not require heating, such as under built-in wardrobes, baths and shower cubicles.

The diagram below illustrates a typical layout that might be considered.

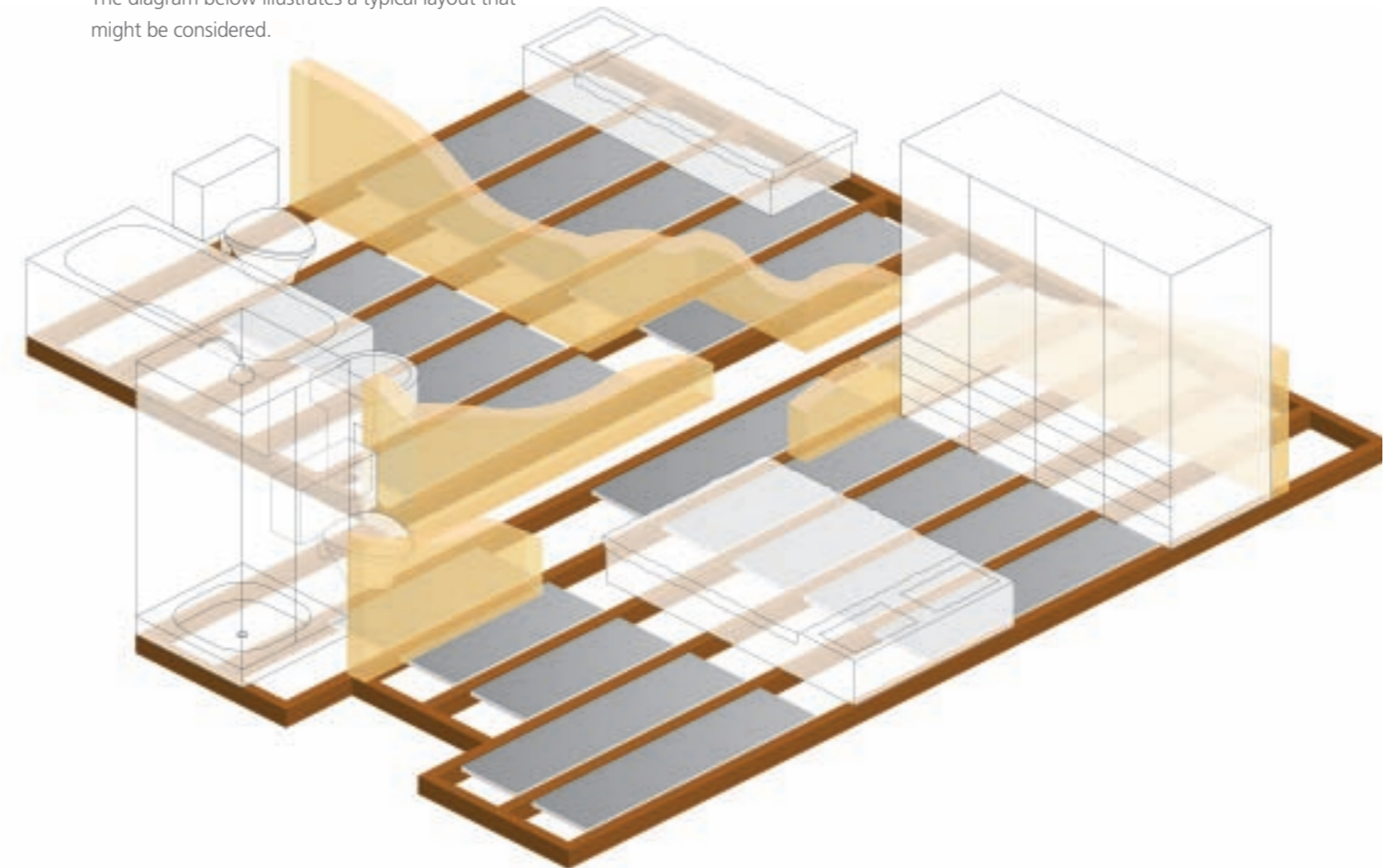

Arrangement	Span
1 x 1.3m Panel	1.4m to 2.2m
1 x 2.0m Panel	2.2m to 2.8m
2 x 1.3m Panels	2.8m to 3.5m
1 x 1.3m Panel + 1 x 2.0m Panel	3.5m to 4.2m
2 x 2.0m Panels	4.2m to 5.0m

Pre-installation requirements

Planning

Before installing MHP panels ensure you have planned out the positioning of the required panels avoiding all other services such as electrics, gas and water supply.

You will not need to do any specific preparation for the installation in a new build property as there will be no ceilings or floors in place.

For existing room refurbishment, you will need to take up your floor if fitting from above or take down the ceiling if fitting from below. Ensure that the area where the MHP panels are to be positioned is free from any debris before commencing installation.

Installation

Installation from above

To install MHP panels from above simply fit support bearers to each side of the joists. These support bearers should be positioned 30mm from the top of the joist and the MHP panel is then simply laid on to these supports.

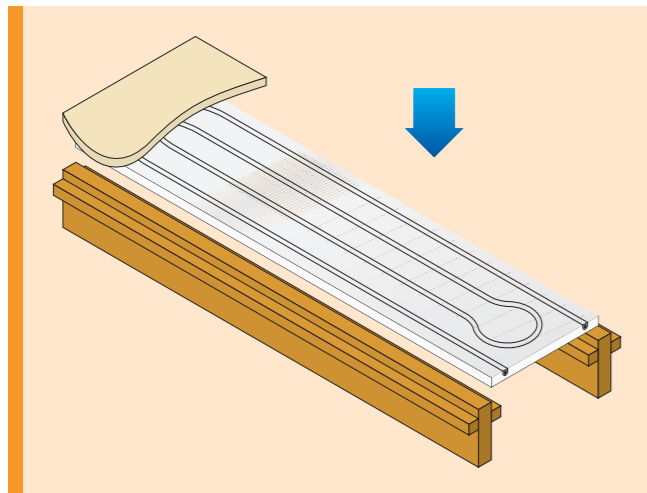

Installation from below

When installing MHP panels from below you will need to mark out the positioning of the panels to ensure you have them situated in the correct places for heating the room above.

Once you have checked the marked out positioning, the MHP panels can be slotted into place and fixed to the underside of the floor using 1 3/4" x 8 woodscrews with M6 x 30 dia washers. It is advisable to use 6 fixings per panel ensuring you avoid the moulded pipe marking on the underside of the panel and fix each panel securely.

IMPORTANT NOTE: Polystyrene can cause deterioration to cable insulation when it comes into direct contact with it. Always ensure that electrical cables are not in physical contact with the MHP panels using tape or a polythene strip.

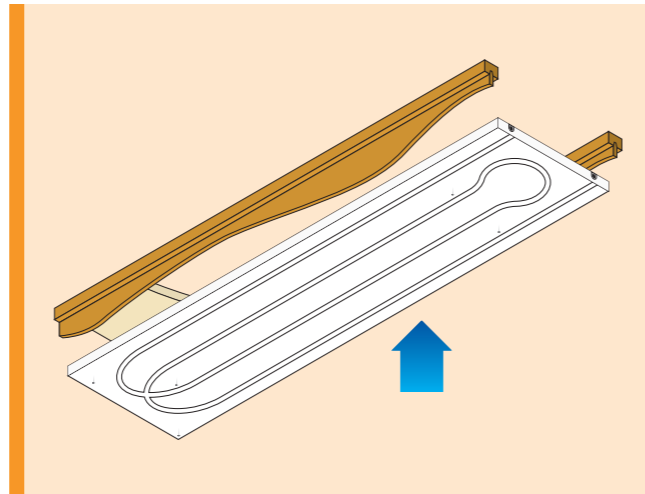

Finishing

Once you have connected your system up to the manifold and tested it you can then finish the room by fitting the floor or ceiling in the normal way depending on whether you have installed MHP from above or below.

Testing

Where possible installations should be tested at 20°C to 18 bar pressure. Any installations once connected to the manifold have a maximum test pressure of 6 bar.

Panel layouts

1 panel layout

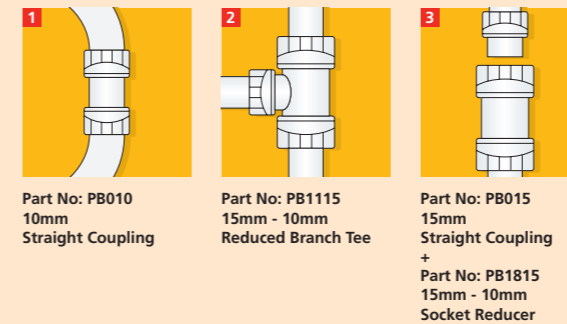
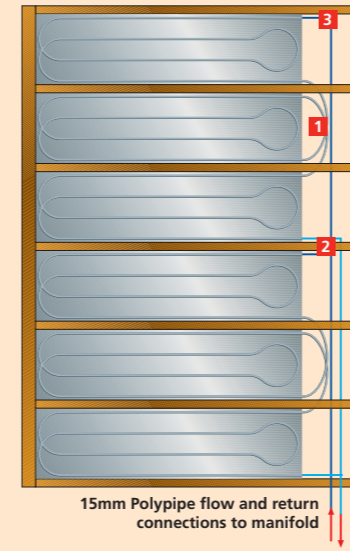

2 panel layout

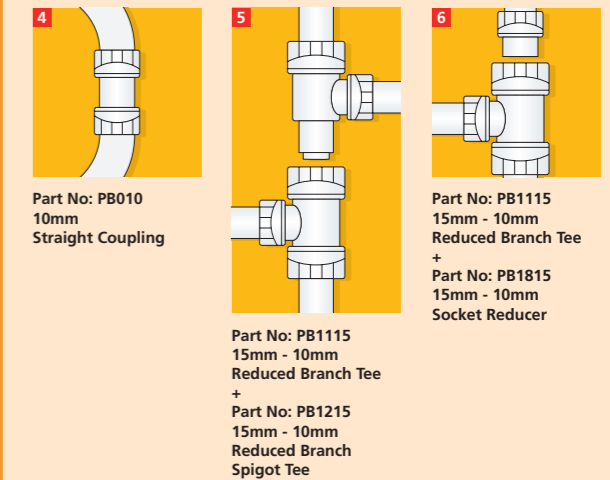
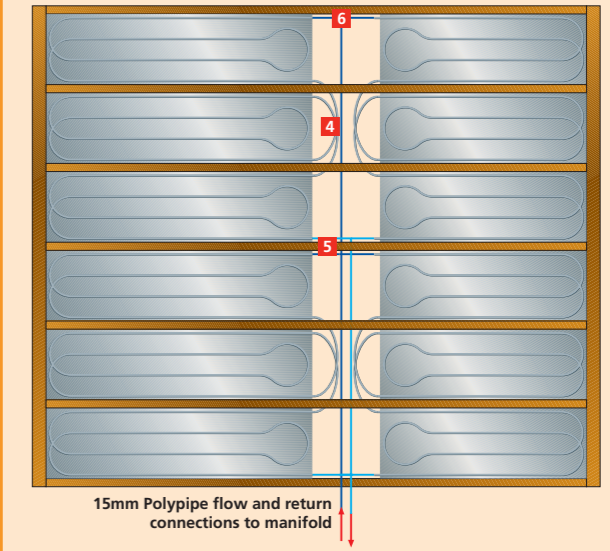

Product Information

Product	Code	No of panels per pack
MHP 490mm (W) x 2.0m (L)	MHP49020	5
MHP 490mm (W) x 1.3m (L)	MHP49013	5
MHP 380mm (W) x 2.0m (L)	MHP38020	5
MHP 380mm (W) x 1.3m (L)	MHP38013	5

Heat Output

Maximum floor area for flow and return 20m²

Room at 20°C		Heat output per panel			
Flow temp (°C)	Av. floor temp (°C)	MHP49020 (W)	MHP49013 (W)	MHP38020 (W)	MHP38013 (W)
40	25.0	63	42	49	33
45	25.8	75	50	58	39
50	26.6	86	58	67	45
55	28.9	120	80	93	62
60	30.8	147	99	114	77

Approximate coverage required:

For 70W/m² room = 80% coverage

For 50W/m² room = 60% coverage

Connect up to 3 panels in series

Maximum coverage per circuit 20m²