

**Polypipe Ltd**  
**t/a Polypipe Building Products**

Broomhouse Lane  
Edlington  
Doncaster DN12 1ES

Tel: 01709 770000 Fax: 01709 770001

e-mail: info@polypipe.com

website: www.polypipe.com



**Agrément Certificate**

**89/2206**

Product Sheet 6

**POLYPIPE UNDERGROUND DRAINAGE SYSTEM**

**POLYPIPE INSPECTION CHAMBER SYSTEMS**

This Agrément Certificate Product Sheet<sup>(1)</sup> relates to Polypipe Inspection Chamber Systems, comprising 460 by 610 mm rectangular, 320 and 460 mm diameter polypropylene units and ancillaries for means of access to drains to a depth of 1.2 m in non-roadway applications for the purpose of testing, rodding and removal of debris.

(1) Hereinafter referred to as 'Certificate'.

**CERTIFICATION INCLUDES:**

- factors relating to compliance with Building Regulations where applicable
- factors relating to additional non-regulatory information where applicable
- independently verified technical specification
- assessment criteria and technical investigations
- design considerations
- installation guidance
- regular surveillance of production
- formal three-yearly review.



**KEY FACTORS ASSESSED**

**Flow characteristics** — the systems have sufficient flow characteristics to prevent blockage (see section 6).

**Strength** — the systems have adequate strength to resist loads and impact likely to be encountered during transport, installation and use (see section 7).

**Performance of joints** — the connections between the chamber and the pipelines are watertight, and the traps are airtight (see section 8).

**Durability** — the material from which the systems are manufactured will not deteriorate significantly and the anticipated service life of the systems will be in excess of 50 years (see section 13).

The BBA has awarded this Certificate to the company named above for the systems described herein. These systems have been assessed by the BBA as being fit for their intended use provided they are installed, used and maintained as set out in this Certificate.

On behalf of the British Board of Agrément

Date of Third issue: 14 July 2022

Originally certificated on 29 March 1989

Hardy Giesler  
Chief Executive Officer

*The BBA is a UKAS accredited certification body – Number 113.*

*The schedule of the current scope of accreditation for product certification is available in pdf format via the UKAS link on the BBA website at www.bbacerts.co.uk  
Readers are advised to check the validity and latest issue number of this Agrément Certificate by either referring to the BBA website or contacting the BBA direct.  
Any photographs are for illustrative purposes only, do not constitute advice and should not be relied upon.*

**British Board of Agrément**

Bucknalls Lane  
Watford  
Herts WD25 9BA

©2022

tel: 01923 665300  
clientservices@bbacerts.co.uk  
www.bbacerts.co.uk

## Regulations

In the opinion of the BBA, Polypipe Inspection Chamber Systems, if installed, used and maintained in accordance with this Certificate, can satisfy or contribute to satisfying the relevant requirements of the following Building Regulations (the presence of a UK map indicates that the subject is related to the Building Regulations in the region or regions of the UK depicted):



### The Building Regulations 2010 (England and Wales) (as amended)

<b>Requirement:</b>	<b>H1(1)</b>	<b>Foul water drainage</b>
Comment:		The systems will convey the flow of foul or surface water and minimise the risk of blockages or leakage. See sections 4.1, 6, 7, 8 and 9 of this Certificate.
<b>Requirement:</b>	<b>H3(3)</b>	<b>Rainwater drainage</b>
Comment:		The systems will convey the flow of foul or surface water and minimise the risk of blockages or leakage. See sections 4.1, 6, 7, 8 and 9 of this Certificate.
<b>Regulation:</b>	<b>7(1)</b>	<b>Materials and workmanship</b>
Comment:		The systems are acceptable. See section 13 and the <i>Installation</i> part of this Certificate.



### The Building (Scotland) Regulations 2004 (as amended)

<b>Regulation:</b>	<b>8(1)(2)</b>	<b>Durability, workmanship and fitness of materials</b>
Comment:		The systems satisfy the requirements of this Regulation. See sections 12 and 13 and the <i>Installation</i> part of this Certificate.
<b>Regulation:</b>	<b>9</b>	<b>Building standards applicable to construction</b>
Standard:	3.6	Surface water drainage
Standard:	3.7	Waste water drainage
Comment:		The systems will satisfy the relevant requirements of these Standards, with reference to clauses 3.6.1 <sup>(1)(2)</sup> to 3.6.3 <sup>(1)(2)</sup> , 3.7.3 <sup>(1)(2)</sup> and 3.7.4 <sup>(1)(2)</sup> . See sections 4.1, 6, 7, 8 and 9 of this Certificate.
Standard:	7.1(a)	Statement of sustainability
Comment:		The systems will contribute to meeting the relevant requirements of Regulation 9, Standards 1 to 6, and therefore will contribute to a construction meeting a bronze level of sustainability as defined in this Standard.
<b>Regulation:</b>	<b>12</b>	<b>Building standards applicable to conversions</b>
Comment:		All comments given for the systems under Regulation 9, Standards 1 to 6 also apply to this Regulation, with reference to clause 0.12.1 <sup>(1)(2)</sup> and Schedule 6 <sup>(1)(2)</sup> .

(1) Technical Handbook (Domestic).

(2) Technical Handbook (Non-Domestic).



### The Building Regulations (Northern Ireland) 2012 (as amended)

<b>Regulation:</b>	<b>23(1)(a)(i)</b>	<b>Fitness of materials and workmanship</b>
Comment:	<b>(iii)(b)(i)</b>	The systems are acceptable. See section 13 and the <i>Installation</i> part of this Certificate
<b>Regulation:</b>	<b>79</b>	<b>Drainage systems</b>
Comment:		The systems are acceptable. See sections 4.1, 6, 7, 8 and 9 of this Certificate.
<b>Regulation:</b>	<b>81(a)</b>	<b>Underground foul drainage</b>
Comment:		The systems will convey the flow of foul or surface water and minimise the risk of blockages or leakage. See sections 4.1, 6, 7, 8 and 9 of this Certificate.

<b>Regulation:</b>	<b>82(a)</b>	<b>Rainwater drainage</b>
<b>Comment:</b>	The systems will convey the flow of rainwater and minimise the risk of blockages or leakage. See sections 4.1, 6, 7,8 and 9 of this Certificate.	

## Construction (Design and Management) Regulations 2015 Construction (Design and Management) Regulations (Northern Ireland) 2016

Information in this Certificate may assist the client, designer (including Principal Designer) and contractor (including Principal Contractor) to address obligations under these Regulations.

See section: 3 *Delivery and site handling* (3.2) of this Certificate.

### Additional Information

#### NHBC Standards 2022

In the opinion of the BBA, Polypipe Inspection Chamber Systems, if installed, used and maintained in accordance with this Certificate, can satisfy or contribute to satisfying the relevant requirements in relations to *NHBC Standards*, Chapter 5.3 *Drainage below ground*.

### Technical Specification

#### 1 Description

1.1 Polypipe Inspection Chamber Systems comprise 460 x 610 mm Rectangular, 320 mm and 460 mm Diameter systems (see Table 1 and 2):

- base unit — black injection-moulded polypropylene with side inlets incorporating seals to BS EN 681-1 : 1996, Type WC, retained by polypropylene snap caps
  - 460 x 610 mm — with integral benching (see Figure 1a)
  - 320 mm — with integral benching, a straight inlet and one outlet (see Figure 1b)
  - 460 mm (see Figure 1c):
    - 110 mm — with open channels, a straight inlet and one outlet
    - 110 mm/160 mm — with a main channel with 160 mm inlet and outlet sockets
- risers — black injection-moulded polypropylene. The maximum invert depth of the chamber is dependent on the number of risers (see Table 3)
- EPDM rubber seals — to BS EN 681-1 : 1996, Type WC, available separately (with exception of the 460 x 610 mm rectangular base). The seals are fitted into grooves on the outside of the risers to make watertight joints between risers and bases/risers. Some SKUs feature one piece integrally moulded seal housing grooves
- cover — supplied with frame.

**Table 1 Characteristics of the inspection chambers**

Element	Characteristic (unit)	460 x 610 mm	320 mm	460 mm	
Base unit	Number of side inlets	4	2	4 (2 x 45° and 2 x 90°)	
	Inlet dimension (mm)	110	110	110	45° x 110 and 90°x 160
	Wall thickness (mm)	4	4	4	
	Invert level (mm)	330	170	220	250
	No of blanking plugs supplied	3	2	3	2 x 110 and 2 x 160
Riser	Internal dimension (mm)	460 x 610	320	460	
	Wall thickness (mm)	8	4	4	
	Depth (mm)	180	135	215	
Cover	Material	Pressed steel <sup>(1)</sup>	PP	Cast iron <sup>(2)</sup>	Concrete
	Dimensions (mm)	470 x 620	320	493	490
Frame	Material	PP	PP	Cast iron <sup>(2)</sup>	PP

(1) To BS EN 10143 : 2006.

(2) To BS EN 1561 : 2011 coated with cold applied black bitumen to BS 3416 : 1991.

**Table 2 Product codes of the elements covered by this Product Sheet**

Element	Product Code (Alternative code)				
	460 x 610 mm	320 mm	460 mm		
Base unit	UG490	UG437 (4DI1702B)	UG440 DN110 (4DI240B)	UG670 DN110/160 (64DI240B)	
Riser	UG491	UG438/UG466 (4DI135R)	UG431 (4DI215R)		
Seal	—	UG388/UG388B	UG488 (4DI215S)		
Cover with frame	UG496	UG501 round UG502 square	UG419 Cast iron with cast iron	UG444 Cast iron with PP	UG497 Concrete with PP

**Figure 1 Polypipe Inspection Chamber Systems**

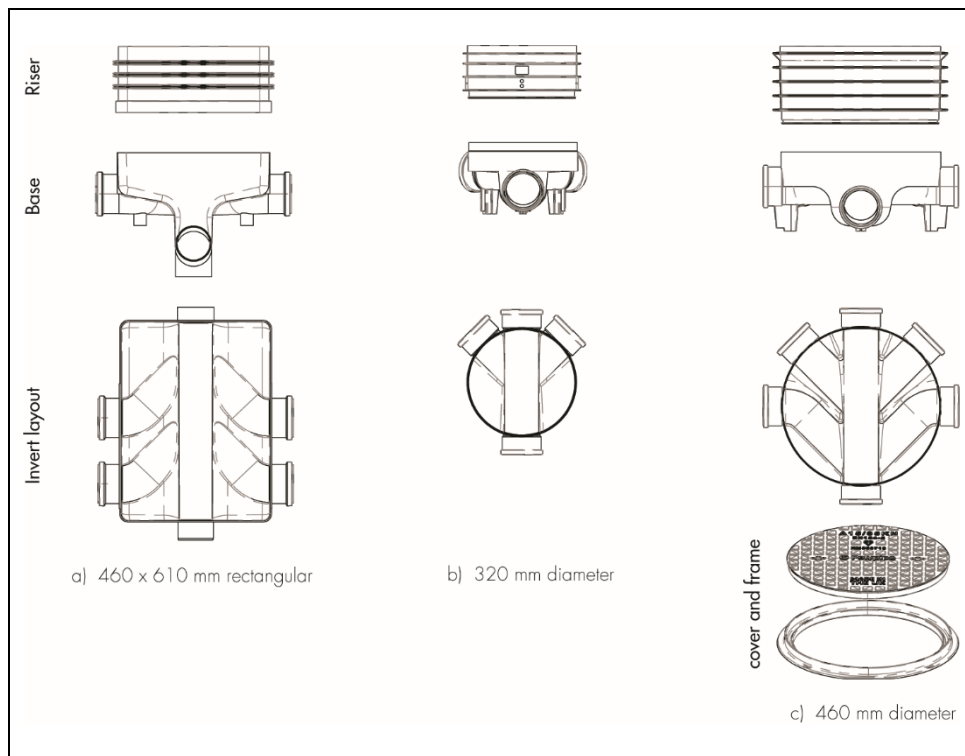

*Table 3 Invert depth for the chamber systems*

Configuration	Maximum invert depth (mm)			
	460 x 610 mm	320 mm	460 mm	
Base unit only	330	170	220	250
Base plus one riser	450	314	413	443
Base plus two risers	600	457	606	636
Base plus three risers	750	600	799	829
Base plus four risers	900	—	992	1022
Base plus five risers	1050	—	1185	1200

1.2 Sealant (not covered by this Certificate) conforming to BS EN ISO 11600 : 2003 may be used for jointing the riser sections. The Manufacturer's installation instructions must be followed in this case.

## 2 Manufacture

2.1 Base units, risers, frames and covers (as detailed in Table 1) are injection-moulded from polypropylene.

2.2 As part of the assessment and ongoing surveillance of product quality, the BBA has:

- agreed with the manufacturer the quality control procedures and product testing to be undertaken
- assessed and agreed the quality control operated over batches of incoming materials
- monitored the production process and verified that it is in accordance with the documented process
- evaluated the process for management of nonconformities
- checked that equipment has been properly tested and calibrated
- undertaken to carry out the above measures on a regular basis through a surveillance process, to verify that the specifications and quality control operated by the manufacturer are being maintained.

2.3 The management system of Polypipe Building Products has been assessed and registered as meeting the requirements of BS EN ISO 9001 : 2015 and BS EN ISO 14001 : 2015 by BSI (Certificates FM00318 and EMS 732427 respectively). The management system of Polypipe Ltd has been assessed and registered as meeting the requirements of BS EN ISO 9001 : 2015 by BSI (Certificate FM582230).

## 3 Delivery and site handling

3.1 The inspection chamber bases, risers, seals, and covers/frames are delivered to site unprotected, and therefore reasonable care in handling and storage is required to avoid damage or distortion.

3.2 Handling, storage and transportation should be in accordance with BS 8000-14 : 1989, BS EN 1610 : 2015 and the recommendations of this Certificate.

## Assessment and Technical Investigations

The following is a summary of the assessment and technical investigations carried out on Polypipe Inspection Chamber Systems.

## Design Considerations

### 4 Use



4.1 Polypipe Inspection Chamber Systems provide means of access to drains for testing, rodding and removal of debris. They are satisfactory for use in domestic underground drains and public and private sewers for the conveyance, by combined or separate systems, of surface water or domestic sewage, as is permitted to be discharged into public sewers by the Water Industry Act 1991, and surface water and sewage as is permitted and defined by the Sewerage (Scotland) Act 1968 and the Water and Sewerage Services (Northern Ireland) Order 2006.

4.2 The inspection chambers are for use at depths of up to 1.2 m in areas restricted to pedestrians and pedal cyclists, where Group 1 covers to BS EN 124-1 : 2015 would be suitable. The inspection chamber bases and risers can also be used at depths of up to 1.2 m in footways, pedestrian areas and comparable areas, car parks and car parking decks if a cover and frame Kitemarked to BS EN 124-1 : 2015, Group 2<sup>(1)</sup> covers are used (see the *Installation* part of this Certificate).

(1) Not supplied by the Certificate holder.

4.3 The systems are for use with 110 mm and/or 160 mm PVC-U pipes and fittings to BS EN 1401- 1 : 2019, BS EN 13476-1 : 2018 and BS EN 13476-2 : 2018, or with other products covered by the other Product Sheets of this Certificate.

4.4 110 mm and 110 mm/160 mm base units can also be used as preformed bases in conventional manholes of depths up to 6 m, constructed in accordance with BS EN 752 : 2017 (see the *Installation* part of this Certificate).

4.5 The inspection chambers have not been assessed for the conveyance of trade effluent and such use is outside the scope of this Certificate.

## 5 Practicability of installation

The systems are designed to be installed by a competent general builder, or a contractor, experienced in below-ground drainage work.

## 6 Flow characteristics



The dimensions of the inspection chamber bases will minimise the risk of blockages providing the drainage layout is designed in accordance with BS EN 752 : 2017.

## 7 Strength



7.1 When used with the specified covers and frames, the systems have adequate strength for use in areas where Group 1 covers to BS EN 124-1 : 2015 can be used.

7.2 The systems have adequate strength to withstand the loads associated with normal site handling, installation and drain cleaning operations.

## 8 Performance of joints



8.1 The performance of joints, when correctly made, will not be adversely affected by thermal expansion or contraction.

8.2 Joints with the pipeline remain watertight under conditions of pipeline movement in excess of those expected to occur in normal good drainage practice.

## 9 Watertightness



The assembled inspection chambers and correctly made connections between the inspection chamber and the drain run will not allow seepage of water into or from the surrounding soil.

## 10 Resistance to chemicals

10.1 The systems have adequate resistance to the type and quantity of chemicals likely to be found in domestic sewage.

10.2 Details of the chemical resistance of EPDM rubber are given in PD ISO/TR 7620 : 2005.

## 11 Resistance to elevated temperatures

The inspection chambers and covers have adequate resistance to the normal temperature range of domestic sewage. The resistance will be similar to that of the PVC-U drainage system to which they are connected.

## 12 Maintenance



12.1 Normal rodding of the drain can be carried out using polypropylene rods or similar flexible systems, but care must be taken to avoid damaging the inspection chambers.

12.2 The chambers provide access to the drain for the installation of test equipment.

## 13 Durability



The systems will have a service life equivalent to that of the PVC-U drainage system to which they are connected, ie in excess of 50 years.

## 14 Reuse and recyclability

The systems components are made of polypropylene, or EPDM materials, which can be recycled.

## Installation

### 15 General

15.1 Polypipe Inspection Chamber Systems must be installed in accordance with BS EN 752 : 2017, BS EN 1610 : 2015 and the Certificate holder's installation instructions. Typical installations are shown in Figure 2 of this Certificate.

15.2 Precautions must be taken to protect the inspection chambers, covers and frames from damage by construction site traffic.

### 16 Procedure

16.1 The inspection chamber bases must be installed horizontally and bedded on a 100 mm layer of granular material or selected as-dug material. If concrete is used, the inspection chamber should be bedded into position whilst the concrete is still wet, so that the concrete takes the shape of the inspection chamber base.

16.2 The inspection chamber bases are supplied with removable blanking caps which are used to seal off any unused connections. Blanking caps are also available separately, should it be necessary to blank-off more sockets in the 460 mm diameter or the 460 mm by 610 mm chambers.

16.3 PVC-U pipe of 110 or 160 mm diameter, as appropriate, with spigot suitably chamfered, deburred, cleaned and lubricated with silicone lubricant, is pushed fully into the socket of the inspection chamber then withdrawn by 10 mm to allow for expansion movement.

16.4 For the 460 by 610 mm rectangular chamber, it is essential that a continuous bead of silicone sealant to BS EN ISO 11600 : 2003 is applied to the groove of the riser prior to assembly, to ensure a watertight joint is obtained.

16.5 For the 460 mm diameter chamber, seals are fitted into the riser grooves, and the socket of the inspection chamber/riser is lubricated with silicone lubricant to obtain a watertight joint.

16.6 The maximum number of riser pieces fitted to the chamber bases and the maximum invert depths are given in Table 3.

16.7 The top of the uppermost riser may be cut to the required levels.

16.8 Backfilling is carried out using granular material as described in section 16.1, around and up to a level 100 mm above the inlet and outlet pipes. Thereafter, selected site material free from stones larger than 25 mm and clay lumps larger than 75 mm should be placed and consolidated around the chamber. During backfilling, the chamber should be covered to prevent the ingress of foreign matter into the drain.

16.9 For Group 1 load situations, the inspection chamber assembly is fitted with one of the Polypipe cover and frame options (see section 1.3) and installed as shown in Figures 2 and 3. For Group 2 load situations, the inspection chamber assembly is installed as shown in Figure 4, using a Group 2 cover and frame Kitemarked to BS EN 124-1 : 2015 (not supplied by the Certificate holder).

**Figure 2 Group 1 inspection cover installation details for the systems**

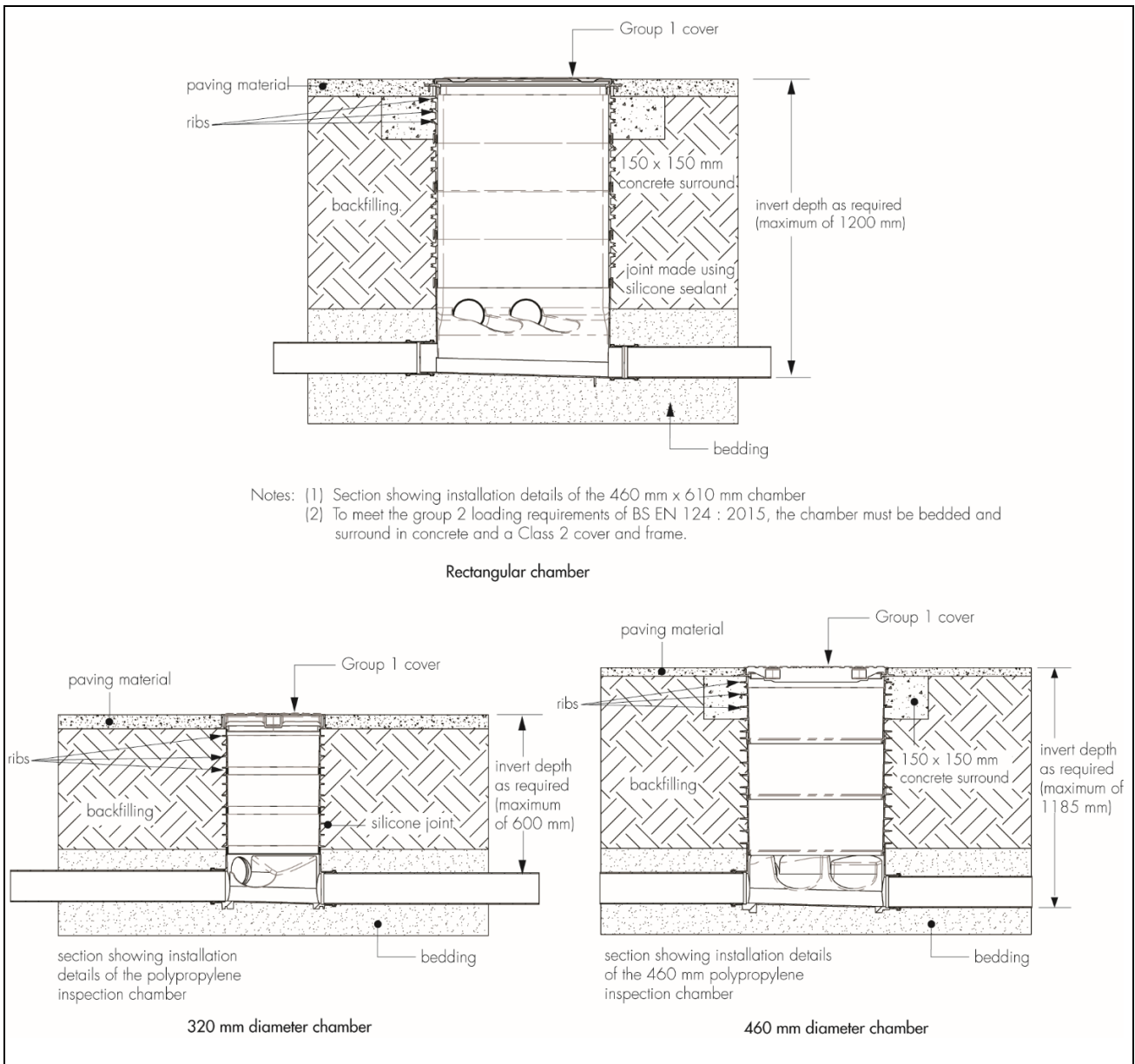

16.10 The rectangular and 460 mm diameter chamber base units may be used as preformed bases in conventional manholes up to 6 m deep and constructed in accordance with BS EN 752 : 2017. The units should be bedded on, and surrounded with, concrete suitably designed to support the shaft, which may be of brickwork or standard concrete sections.

16.11 If the inspection chamber is to be installed in ground where the water table may rise above the invert level of the chamber, it must be completely surrounded in concrete.



**Figure 3 Group 1 inspection cover installation details for the Polypipe 460 mm Diameter Inspection Chamber**

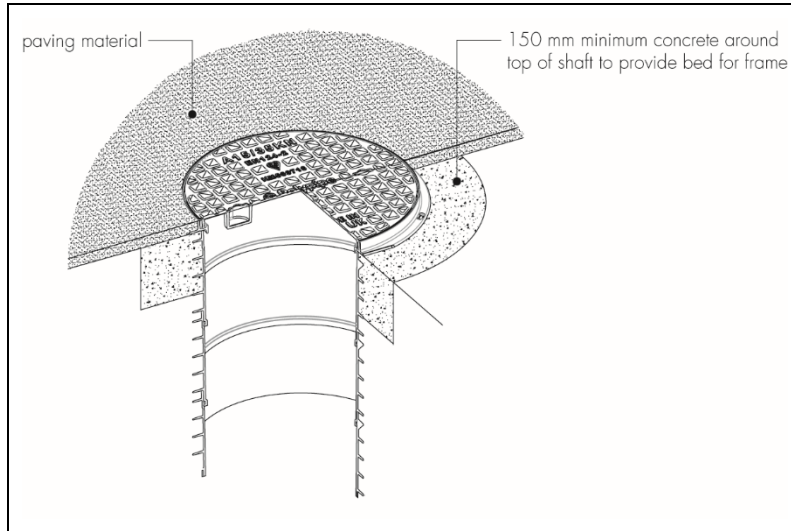

**Figure 4 Typical installation detail of inspection chamber**

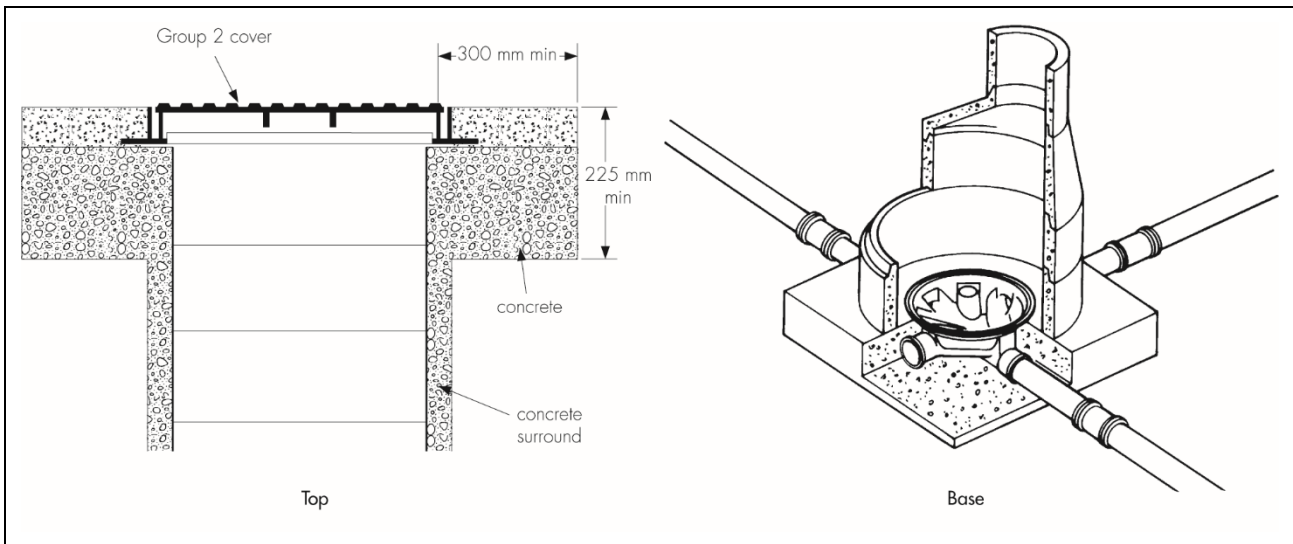

## Technical Investigations

### 17 Tests

17.1 Tests were carried out on the Polypipe 460 mm and 610 mm Rectangular Inspection Chamber System to determine:

- effect of thermal cycling
- practicability of rodding the chamber using polypropylene drain rods with various rodding heads
- practicability of drain testing using screw expanding and inflatable stoppers at maximum permitted depth
- dimensional accuracy
- leak tightness of joints under conditions of deformation
- effect of loads on cover and frame assembly
- angular movement, ie rocking of cover within frame.

17.2 Tests were carried out on the Polypipe 320 mm and 460 mm Diameter Inspection Chamber System to determine:

- effect of combination of hot and cold water discharges through the chamber whilst the cover was subjected to a 250 kg load
- practicability of rodding the chamber using polypropylene drain rods with various rodding heads
- practicability of drain testing using screw expanding and inflatable stoppers at maximum permitted depth
- dimensional accuracy
- leaktightness of joints under conditions of deformation and angular deflection.
- effect of loads on each cover and frame assembly (460 mm only)
- angular movement, ie rocking of cover within frame
- specific tangential initial stiffness of risers (460 mm only).

17.3 Tests were carried out and the results assessed to determine material properties:

- melt flow index
- density
- tensile strength
- environmental stress cracking resistance
- long-term creep.

## **18 Investigations**

18.1 An evaluation was made of existing data to determine:

- resistance to chemicals
- environmental stress cracking resistance
- ease of jointing
- durability.

18.2 An assessment was made of the flow characteristics, ease of cleaning and resistance to blockage.

18.3 The manufacturing process was evaluated, including the methods adopted for quality control, and details were obtained of the quality and composition of the materials used.

18.4 Site visits were conducted to assess the practicability of installation and rodding.

## Bibliography

BS 3416 : 1991 *Specification for bitumen-based coatings for cold application, suitable for use in contact with potable water*

BS 8000-14 : 1989 *Workmanship on building sites — Code of practice for below ground drainage*

BS EN 124-1 : 2015 *Gully tops and manhole tops for vehicular and pedestrian areas. Definitions, classification, general principles of design, performance requirements and test methods*

BS EN 681-1 : 1996 *Elastomeric seals — Material requirements for pipe joint seals used in water and drainage applications — Vulcanized rubber*

BS EN 752 : 2017 *Drain and sewer systems outside buildings*

BS EN 1401-1 : 2019 *Plastics piping systems for non-pressure underground drainage and sewerage — Unplasticized poly(vinylchloride) (PVC-U) — Specifications for pipes, fittings and the system*

BS EN 1561 : 2011 *Founding — Grey cast irons*

BS EN 1610 : 2015 *Construction and testing of drains and sewers*

BS EN 10143 : 2006 *Continuously hot-dip coated steel sheet and strip — Tolerances on dimensions and shape*

BS EN 13476-1 : 2018 *Plastics piping systems for non-pressure underground drainage and sewerage — Structured-wall piping systems of unplasticized poly(vinyl chloride) (PVC-U), polypropylene (PP) and polyethylene (PE) — General requirements and performance characteristics*

BS EN 13476-2 : 2018 *Plastics piping systems for non-pressure underground drainage and sewerage — Structured-wall piping systems of unplasticized poly(vinyl chloride) (PVC-U), polypropylene (PP) and polyethylene (PE) — Specifications for pipes and fittings with smooth internal and external surface and the system, Type A*

BS EN ISO 9001 : 2015 *Quality management systems — Requirements*

BS EN ISO 14001 : 2015 *Environmental management systems — Requirements with guidance for use*

BS EN ISO 11600 : 2003 + A1 : 2011 *Building construction — Jointing products — Classification and requirements for sealants*

PD ISO/TR 7620 : 2005 *Rubber materials — Chemical resistance*

### 19 Conditions

#### 19.1 This Certificate:

- relates only to the product/system that is named and described on the front page
- is issued only to the company, firm, organisation or person named on the front page – no other company, firm, organisation or person may hold or claim that this Certificate has been issued to them
- is valid only within the UK
- has to be read, considered and used as a whole document – it may be misleading and will be incomplete to be selective
- is copyright of the BBA
- is subject to English Law.

19.2 Publications, documents, specifications, legislation, regulations, standards and the like referenced in this Certificate are those that were current and/or deemed relevant by the BBA at the date of issue or reissue of this Certificate.

19.3 This Certificate will remain valid for an unlimited period provided that the product/system and its manufacture and/or fabrication, including all related and relevant parts and processes thereof:

- are maintained at or above the levels which have been assessed and found to be satisfactory by the BBA
- continue to be checked as and when deemed appropriate by the BBA under arrangements that it will determine
- are reviewed by the BBA as and when it considers appropriate.

19.4 The BBA has used due skill, care and diligence in preparing this Certificate, but no warranty is provided.

19.5 In issuing this Certificate the BBA is not responsible and is excluded from any liability to any company, firm, organisation or person, for any matters arising directly or indirectly from:

- the presence or absence of any patent, intellectual property or similar rights subsisting in the product/system or any other product/system
- the right of the Certificate holder to manufacture, supply, install, maintain or market the product/system
- actual installations of the product/system, including their nature, design, methods, performance, workmanship and maintenance
- any works and constructions in which the product/system is installed, including their nature, design, methods, performance, workmanship and maintenance
- any loss or damage, including personal injury, howsoever caused by the product/system, including its manufacture, supply, installation, use, maintenance and removal
- any claims by the manufacturer relating to CE marking.

19.6 Any information relating to the manufacture, supply, installation, use, maintenance and removal of this product/system which is contained or referred to in this Certificate is the minimum required to be met when the product/system is manufactured, supplied, installed, used, maintained and removed. It does not purport in any way to restate the requirements of the Health and Safety at Work etc. Act 1974, or of any other statutory, common law or other duty which may exist at the date of issue or reissue of this Certificate; nor is conformity with such information to be taken as satisfying the requirements of the 1974 Act or of any statutory, common law or other duty of care.